



**TZ FACADE**  
A s s o c i a t e s

## Titanium Zinc Composite Panels



- **Lightweight**
- **High Strength to Weight Ratio**
- **Long Life Expectancy**
- **Low Maintenance**
- **Durability**
- **Self-Healing Surface**
- **Timeless Classical Appearance**
- **Compatibility**

Facing material supplied by: **RHEINZINK®**



**TZ FACADE**  
A s s o c i a t e s

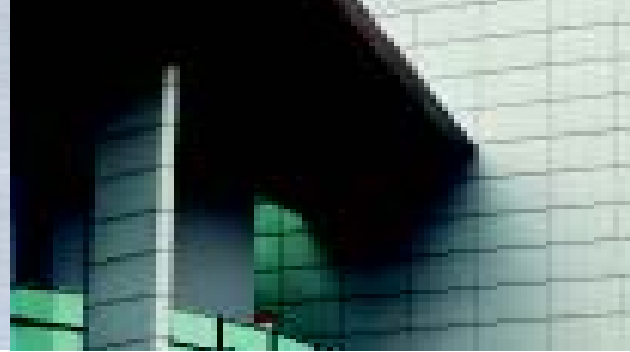

# Stand out from the rest with TZ-Clad's titanium-zinc composite facade materials

## THE COMPANY

**TZ Facade** have sourced and developed a titanium-zinc composite material utilizing "Preweathered" front skin material from world-renowned producer **RHEINZINK®**. The finished article has been developed primarily as a facade material with a wealth of advantages for architects and developers alike.

Creative ideas require inspiration and inspiration begins with the material. Whether used on a new building or the retrofitting of an old one, the combination of a quality surface finish, durability and flexibility of the **TZ-Clad** product makes any building an outstanding landmark of which the owner can be proud.

Image is a number one priority and consumer recognition paramount: **TZ-Clad** can provide that answer for a multitude of applications.

## THE PRODUCT

**TZ-Clad** composite material is formed by laminating a titanium-zinc front skin to a polyethylene core and completed with an aluminium back skin, producing an overall panel thickness of 4mm. It has the attributes of a flat, easily workable and cost effective paneling system for the modern building industry worldwide.

The end result is a product with high strength to weight ratio, lightweight, durable with a long lifespan. The higher strength is achieved by virtue of the composite construction of the material permanently bonded to core and backing sheet.

The continuous lamination process of manufacture ensures an excellent architectural flatness of panel.

It can be equally effective for new construction or for use in retrofitting an existing structure, with little or no modification to the existing structural system required.



*Clockwise from top right:  
Singapore Sports School, Woodlands,  
Singapore; Bluewater Cinema Complex,  
Greenhithe, Great Britain; Kochersberg  
High School, Truchtersheim, France;  
Singapore Sports School, Woodlands,  
Singapore*

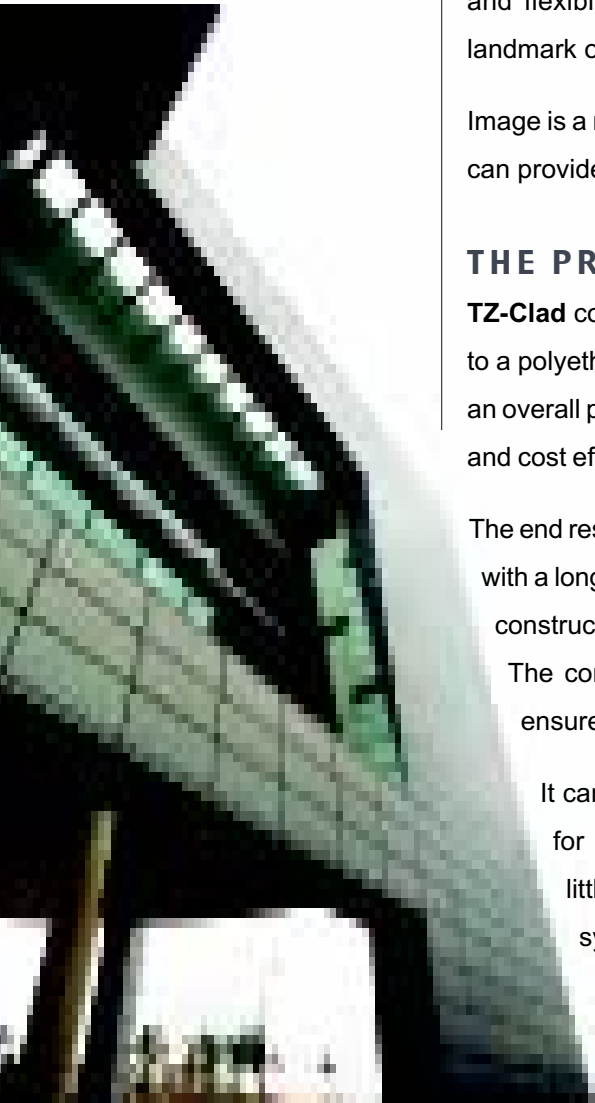

## APPLICATIONS

**TZ-Clad** is ideal for the architect, designer or owner who wants their design to stand out from the rest. It is excellent for transforming or face-lifting an existing building structure, giving the potential for attractive and innovative design, blending well and compatible with other materials.

**TZ-Clad** can be utilized to great effect in both interior and exterior designs. Additionally it is suitable for both new construction and retrofitting of existing buildings.

General applications for **TZ-Clad**, exterior and interior, old or new constructions are:-

- **Curtainwall / Cladding**
- **Column and Beam covers**
- **Canopies**
- **Fascias and Soffits**
- **Parapet Walls**
- **Ceilings**
- **Partitions**



*Singapore Sports School, Woodlands, Singapore*

## ADVANTAGES OF TITANIUM ZINC

Zinc itself is a natural material that is effectively “alive”. Over time, it reacts with the atmosphere to form a protective coating, uniform to the naked eye, formed from basic zinc carbonate – the blue-grey patina.

The unique blue-grey patina colour of the “Preweathered” cannot be replicated by paint or other coatings. Up close, the natural surface variation and grain of the natural metal finish is revealed.

### TIMELESS MATERIAL

Zinc has been used for several centuries and titanium-zinc for approximately three decades. It exudes elegance lending itself to classical designs, and modern designs alike.

### LONG LIFE EXPECTANCY

The titanium-zinc front skin has an expected lifespan of 80-100 years; far outlasting most other materials.

### LOW MAINTENANCE

The high corrosion-resistance of the surface structure caused by atmospheric influences, is the reason why “Preweathered” faced **TZ-Clad** material requires little maintenance or cleaning, keeping costing of building upkeep very low.



*Cargo Lifter Shipyard, Briesen-Brand, Germany*

## SELF-HEALING SURFACE

Should any scratches or stains occur during handling, the panel will heal itself, due to the sacrificial properties of the zinc.

## COMPATIBILITY

The titanium-zinc face of **TZ-Clad** is compatible with a multitude of other materials, most notably aluminium, stainless steel, galvanized steel and lead, materials commonly used in the construction industry.

## COMPOSITE STRUCTURE

The combination of the three different materials which form **TZ-Clad** give a lightweight yet rigid material, with the advantages of providing a flat and smooth panel surface, eliminating possible buckling or oil canning.



## HISTORY

*Zinc has been readily used since the early 1800's in very classical design, valued for its high corrosion resistance and the ease with which it can be finished.*

*Zinc can be viewed as a timeless material, observed in our historical and classical buildings, yet is capable of exuding a modern technical appearance for current and future designs.*



Office Building  
"Trésmi\_afélag"  
Reykjavík,  
Iceland

## FABRICATION

The panel can be easily worked, whether for flat surfaces, sharp angles or curved surfaces, using brake-forming or roll-forming machines. More intricate fabrication techniques that may be used include routing, drilling, punching, shearing, cutting, bolting and riveting.

The tools and techniques associated with ordinary aluminium processing are equally applicable for the fabrication of **TZ-Clad**.



Telenor, Fornebu, Norway

## DESIGN CONSULTATION

**TZ Facade Associates** are able to provide full design assistance services, including architectural detailing, sample mock-ups, fabrication advice and handling instructions to ensure that the product maximizes its potential to provide the best results achievable.

There are a variety of installation systems available, depending on criteria and budget, customizable to your specification.



Clockwise from top left:  
RHEINZINK FRANCE SA, Rosenau, France;  
Sport Stadium Wankdorf, Bern, Switzerland;  
Office Building "The Beehive", Culver City, CA, USA;  
Berlin Museum, Jewish Museum, Berlin, Germany;  
Kochersberg High School, Truchtersheim, France;  
Private Residence, Cantù, Italy



## Rout and Return Method

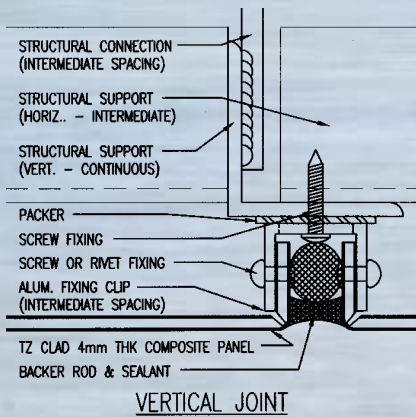

### SPECIFICATIONS

**Panel Overall Thickness:** 4mm

**Front Skin:** Primarily using 0.7mm "Preweathered" titanium- zinc, but also available in bright rolled (weathers to the pleasant blue-grey patina of "Preweathered")

**Core:** Primarily using polyethylene core, but also available with a fire-retardant mineral filled core.

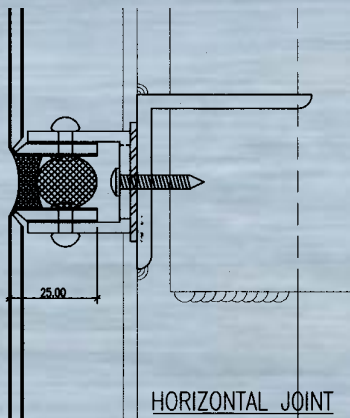

## DESIGN RECOMMENDATIONS

### Rout and Return Method

*(Recommended for interior works with a sealed joint)*

A simple and cost effective construction method. Utilizing fixing clips screwed or riveted to return flange of panel, directly mounted by bolted or screw fixing to structural support system. The exposed clips are then concealed by applying a sealant to the joints.

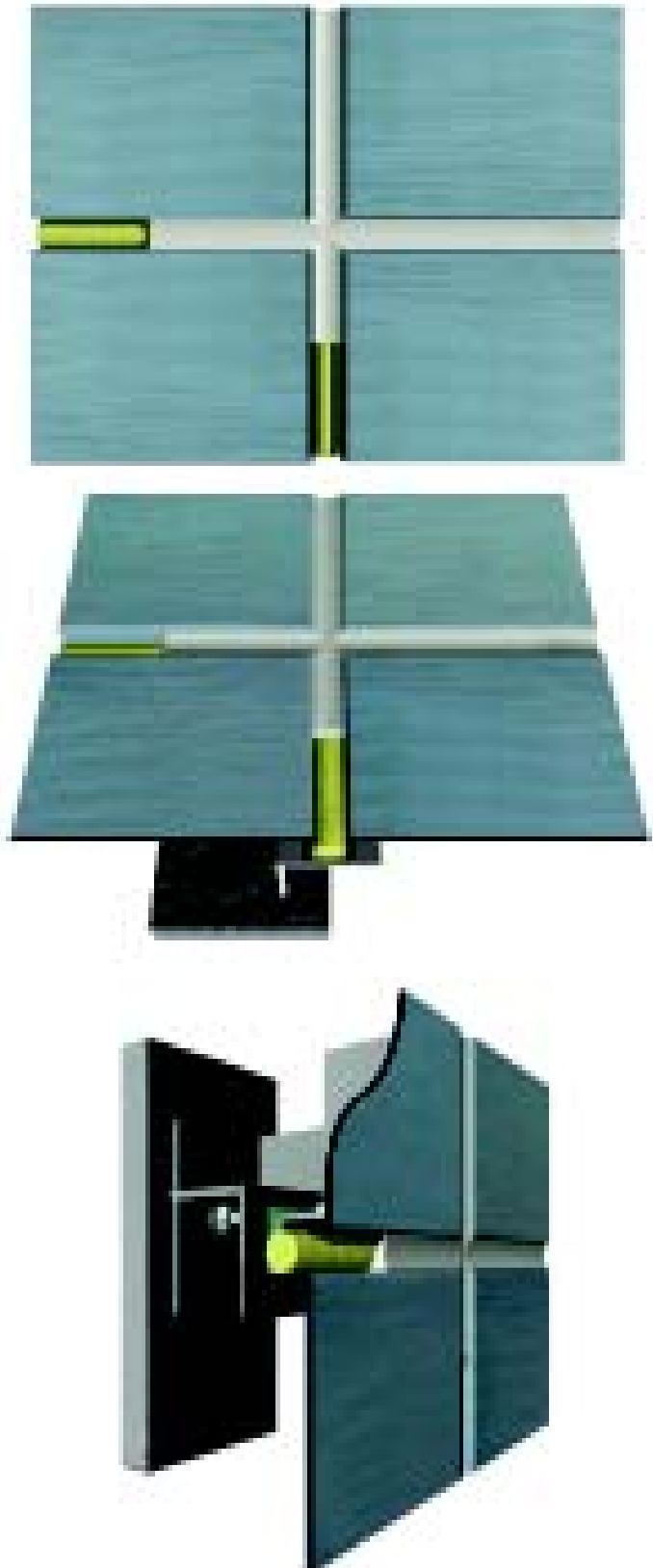

## Continuous Edge Grip Method

*(Recommended for exterior works with open joint)*

A more intricate method, resulting in a pleasing finished installation to the eye. The return flange of the panel is gripped by a specially designed aluminium extrusion system that results in all of the fixing points being concealed away from view. It provides a very attractive and clean finish to the system.

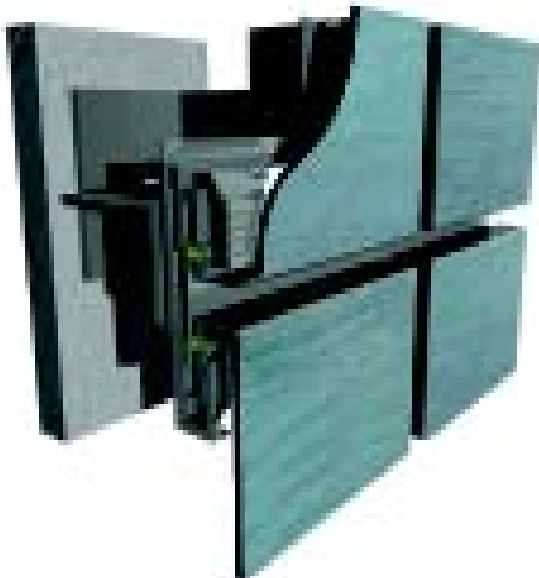
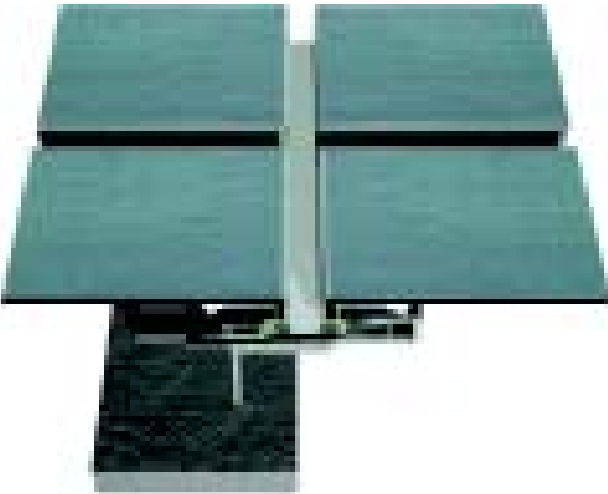

## Continuous Edge Grip Method

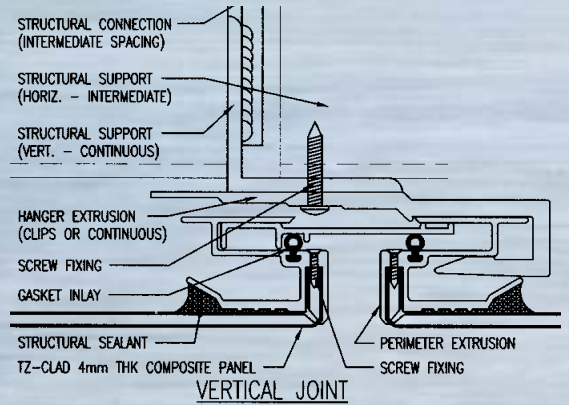

### Back Skin:

0.5mm aluminium, in mill finish or with a service coating.

### Standard Size:

Width 1000mm (maximum)  
Length up to 6000mm (for physical handling constraints, especially at site, a shorter panel length is advised)

Custom width is available but subject to minimum quantity order.

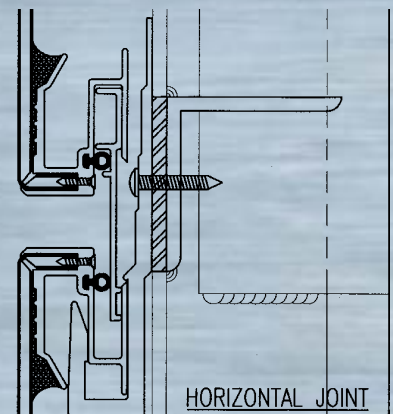

# TZ CLAD - PROPERTIES

CRITERIA	STANDARD	UNITS	DATA
Panel Thickness		mm	4
Weight		kg/m <sup>2</sup>	7.9
Specific Gravity	ASTM D792		1.98
Thermal Expansion	ASTM E831	mm/m/50°C	1.39
Deflection Temperature	ASTM D648	°C	38
Tensile Strength	ASTM E8	kg/mm <sup>2</sup>	4.93
Flexural Strength	ATSM D790	kg/mm <sup>2</sup>	11.2
Flatwise Tensile	ASTM C297	kg/mm <sup>2</sup>	0.46
Flatwise Shear	ASTM D1002	kg/mm <sup>2</sup>	87.0
Minimum Bond Strength	ASTM D1781	mm.N/mm	41.6
Elongation	ATSM E8	%	6
Fire Code Acceptance	BS 476: Part 5 BS 476: Part 6 BS 476: Part 7		Class P Class 0 Class 1
Sound Transmission	ASTM E90	STC Class	26

## TOLERANCES:

Panel Width: ± 2.0mm

Panel Length: ± 4.0mm

Thickness: ± 0.2mm

Bow: max 1% of panel

Squareness: max 5.0mm

## INTERNATIONAL CERTIFICATION AND AWARDS:



CERTIFIED BY THE  
ASSOCIATION FOR  
ENVIRONMENTALLY  
PROVED BUILDING  
PRODUCTS NUMBER OF  
CERTIFICATE Z RHE199



LA-2001-0212-A The results reported herein have been  
LA-2001-0212-F performed in accordance with the  
LA-2001-0214-E laboratory's terms of accreditation under  
LA-2001-0215-B the Singapore Accreditation Council -  
LA-2001-0216-G Singapore Laboratory Accreditation  
LA-2001-0217-G Scheme

## About RHEINZINK® "Preweathered"

Through the development of technology and manufacturing processes, **RHEINZINK®** have carried the evolution of zinc a step further by developing titanium-zinc. The composition of the titanium-zinc sheet consists of electrolytic high-grade zinc with a 99.995% degree purity, alloyed with 1% titanium and 1% copper for malleability and superior performance.

### The Patination Process

On its surface, **RHEINZINK®** forms a blue-grey protective patina. The chemical process of the patina development evolves in several steps. First, zinc oxide forms in contact with the oxygen contained in the air. Through the influence of humidity, zinc hydroxide develops, which reacts with carbon dioxide in the air to

form a dense and adherent patina insoluble in water, consisting of basic zinc carbonate. The blue-grey protective coating provides the zinc material with high corrosion resistance.

Due to its self-regenerating qualities, it reforms by itself in case of damage or abrasion, and therefore requires only low maintenance. "Preweathered" titanium-zinc is also available in bright rolled (weathers to the pleasant blue-grey patina of "Preweathered").

**RHEINZINK®** is the trademark for our zinc copper titanium alloy, specifically developed for the needs of the building industry. Durability, longevity, low maintenance and an elegant, aesthetically pleasing appearance are qualities that make **RHEINZINK®** an ideal building material. **RHEINZINK®** is available in bright rolled and in preweathered formats, the latter has an attractive blue-grey colour that offers the benefits and qualities of natural weathering.

**RHEINZINK®**



**TZ FACADE**  
A s s o c i a t e s

TZ Facade Associates Pte Ltd

140 Robinson Road #06-02A Chow House Singapore 068907 Tel: +65 6327 1211 Fax: +65 6327 1202

Email: info@tzfacade.com Website: www.tzfacade.com